

CREATING POWER SOLUTIONS.

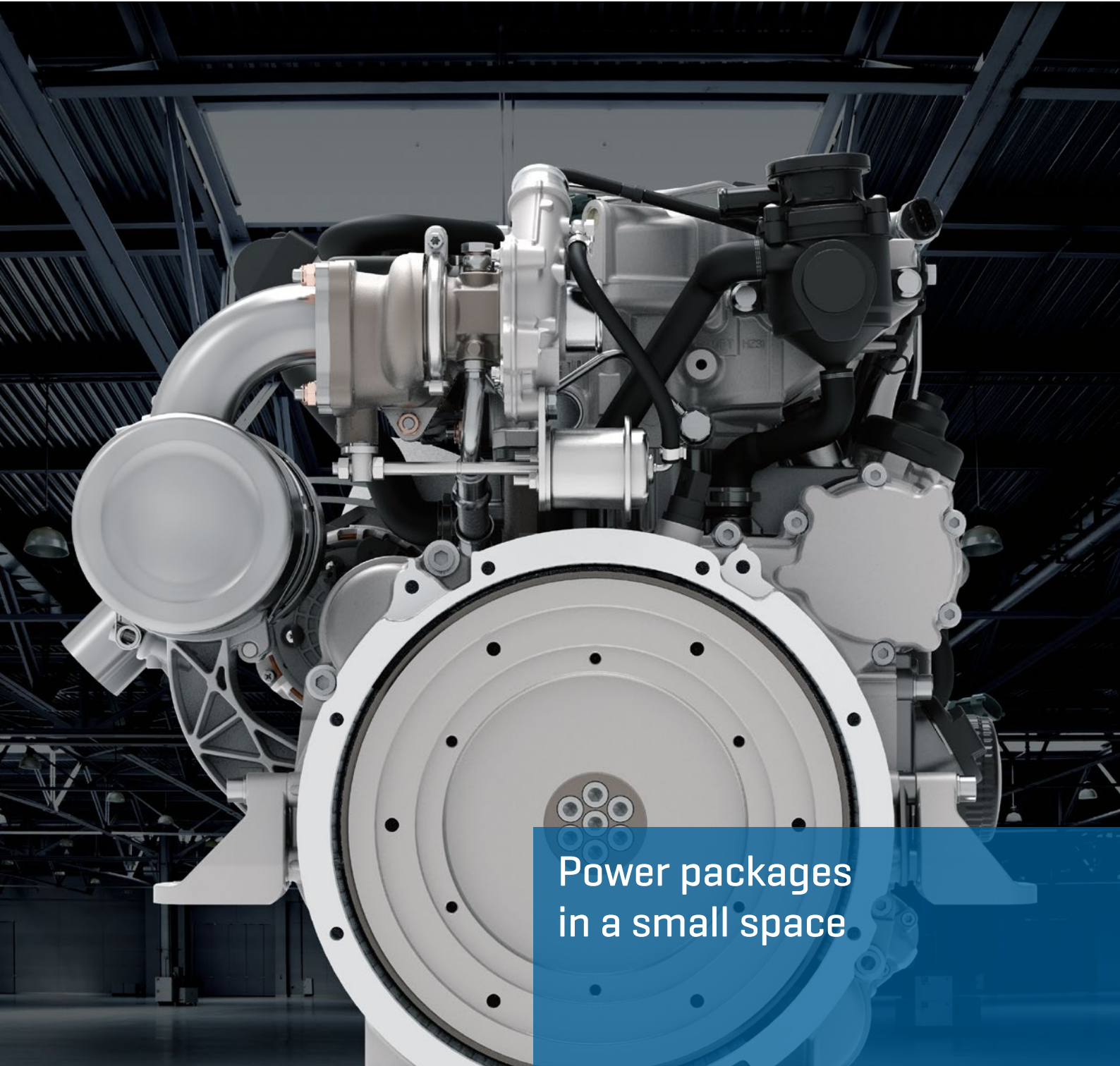

Power packages
in a small space

Hatz H-series diesel engines



The new generation of efficient Hatz diesel engines.

The release of the Hatz H-series started in 2014. Today, the model portfolio embraces various three-cylinder and four-cylinder models. The new generation of compact and efficient industrial engines follows a downsizing approach with common-rail technology and turbocharger.

Supported by:



on the basis of a decision
by the German Bundestag

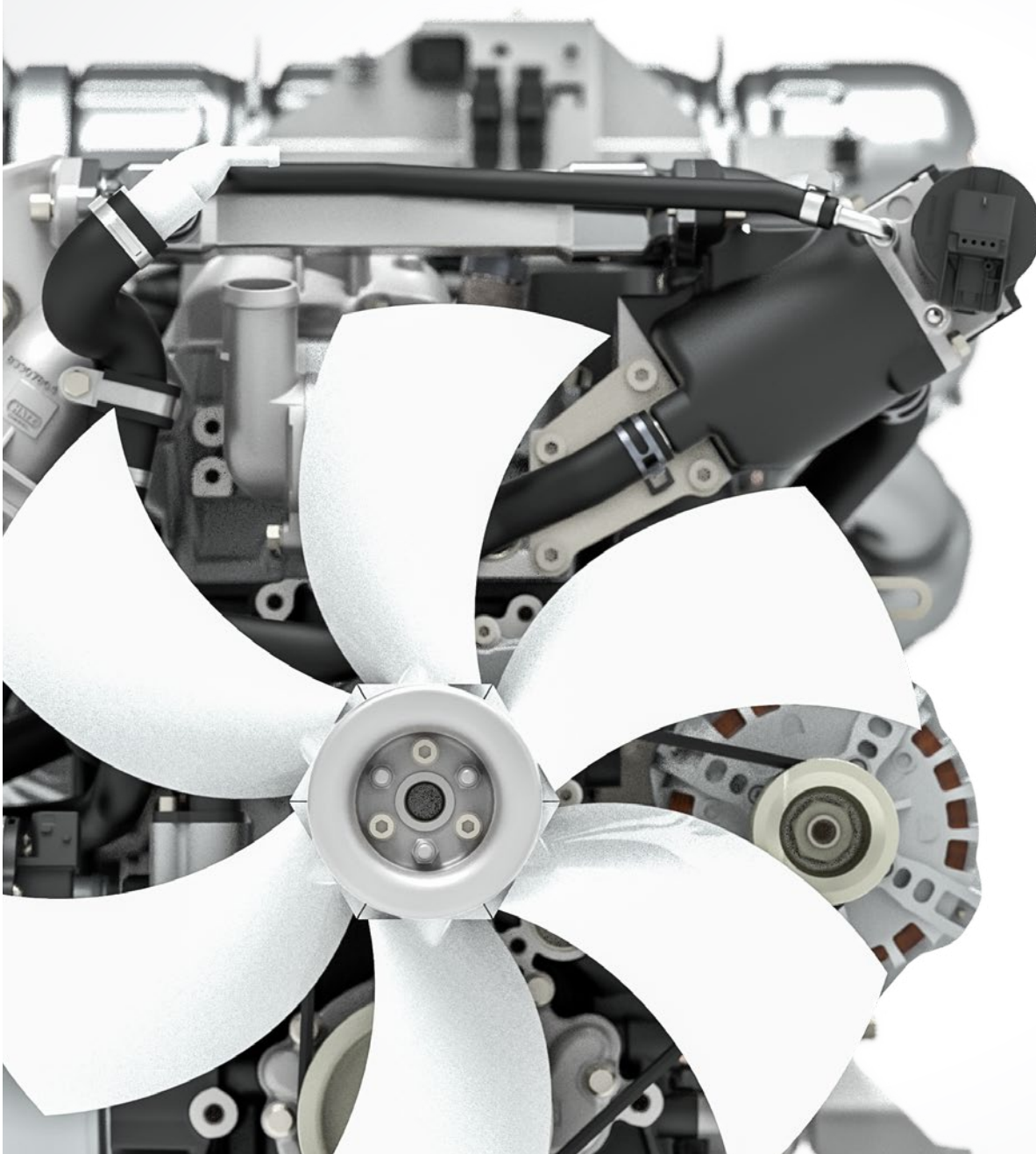

Downsizing approach

A groundbreaking downsizing approach was adopted in development of the H-series engines. The key objectives were the reduction of size and weight with simultaneously higher power and good exhaust gas values. The results are very convincing: Weight and consumption values are lower than those of any other engine in this class. This could be achieved, among other factors, thanks to the iHACS technology [intelligent Hatz Advanced Combustion Strategy] with its sophisticated combustion chamber geometry, Bosch injection technology, minimised friction and a maximum charge air pressure of 1.7 bar.

Conservative-innovative engine for a long service life

All mechanical components were designed and developed with a conservative-innovative approach. The H-series engines are equipped with two valves per cylinder, achieving high efficiency, mechanical robustness and functional simplicity. This is expressed in turn by the familiar long service life. Use of premium products for all important components also underlines this.

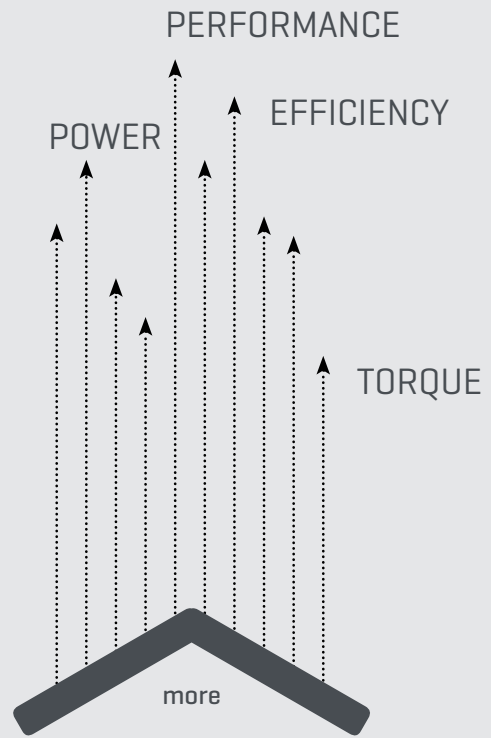

H-series

ROBUST BASIC ENGINE / VARIOUS MODELS

HIGH-QUALITY COMPONENTS

ONE FAMILY COVERS ALL EMISSION STANDARDS

ENGINEERED FOR EU STAGE V & US EPA T4f

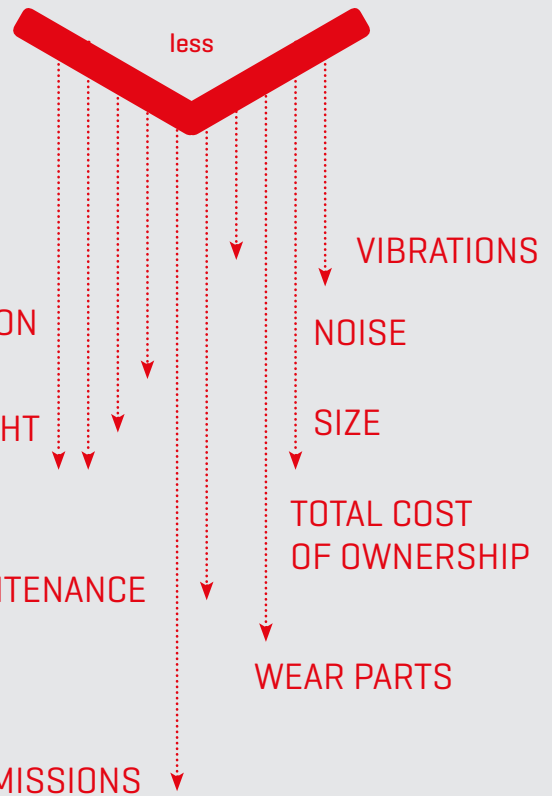

Modern engine family

Compact, light, economical, robust and environmentally friendly: The common-rail diesel engines of the Hatz H-series provide everything expected from powerful and modern industrial engines. They impress through their quiet running, dynamics and maintenance friendliness. Their constantly low fuel consumption over a wide load range sets the benchmark.

Innovation meets reliability. No contradiction for Hatz.

The H-series contains a whole series of technical refinements. They not only distinguish the engines with the most compact dimensions in its class: They also enable best fuel efficiency compared to the competition. Value was placed in particular on the Hatz well-known reliability for every innovation.

Impressive full package

The Hatz 4H50TIC achieved second place in 2015 at the renowned GreenTec Award in the Automobility category.

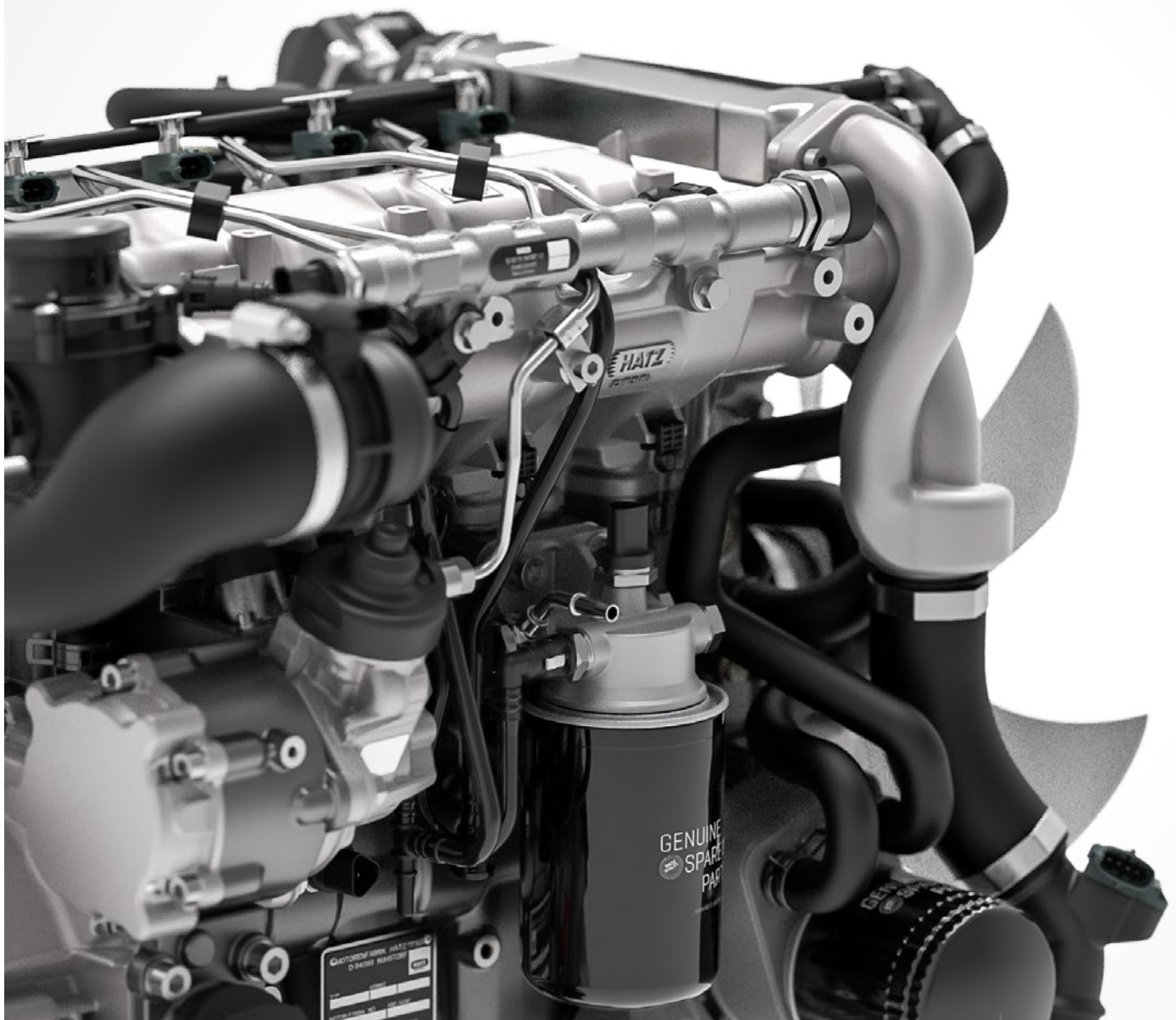

Bosch common-rail system for ultimate fuel efficiency

One of the key factors for the high power density of the H-series is the common-rail system. Hatz opted for the Bosch off-highway CRS, a common-rail system with 1800 bar. It works precisely calculated with pre-, main- and post-injection. Together with the other Bosch components matched ideally to each other – high-pressure pump, injector control unit, and off-highway injectors – the perfect balance is achieved between dynamics, quiet combustion noise, low pollutant levels, and economy.

Real drive consumption close to the optimum

When it comes to fuel efficiency, the Hatz H-series sets new standards for the best point with a specific consumption of just 210 and 220 g/kWh. The special feature here is that consumption values close to the optimum operating point are achieved in a wide load and speed range. This is unrivaled today and makes the Hatz H-series the most efficient engine range in its class.

Optimum combustion strategy for every need

The exhaust gas return system was further developed by Hatz engineers to have a positive effect on the exhaust gas values. A pre-cooling unit for the exhaust gas return (EGR) significantly reduces the exhaust gas temperature before the EGR valve, protecting it against thermal damage. An optimized EGR-mixing-nozzle is also used. It uniformly distributes the recirculated exhaust gases together with the fresh combustion air to all four cylinders. Together with the common rail system, the result is an outstanding exhaust gas quality which ensures that the TIC models are only equipped with a diesel oxidation catalytic converter (DOC) and there is no need for an additional particle filter. Furthermore the engines significantly undercut the emission limits of EPA Tier 4 Final and EU Stage IIIB.

Internal friction

A further key element for the extraordinarily high fuel efficiency is the reduction of internal friction due primarily to the conservative design with only a few moving parts. A major contribution to this is made by the two-valve technology in conjunction with roller tappets as well as the lower camshaft that reduces installation space. Additionally, exclusively high-end materials are used for the conrod and bearings.

Outstanding emission values from the very beginning

Hatz also offers the three-cylinder and four-cylinder TI models that work without EGR and DOC and achieve maximum outputs of 64 kilowatts for countries that do not place special requirements on emission values or in which only fuels with a high sulfur content are available. Compliance with the EPA Tier 2 and EU Stage II emission levels is still achieved without any exhaust gas treatment.

Fit for the strictest limits

The H-family was developed from the very beginning with a focus on fulfilment of tighter regulations, such as EU Stage V that will make a diesel particulate filter (DPF) inevitable. These TICD models are fitted with the customised Hatz diesel particulate filter system optiHEAT that can be optimally adapted to the machine and installation situation.

High maintenance friendliness

A maintenance interval of 500 hours means the engine scores top points with regard to customer friendliness and reliability. The extended intervals are due to hydraulic valve adjustment and large-sized filters. Additionally, the engine has a shut-off sensor system that is able to switch off the engine in an emergency to avoid major damage. The robust construction and careful selection of all components ensure that the engine is fit for the most demanding applications.

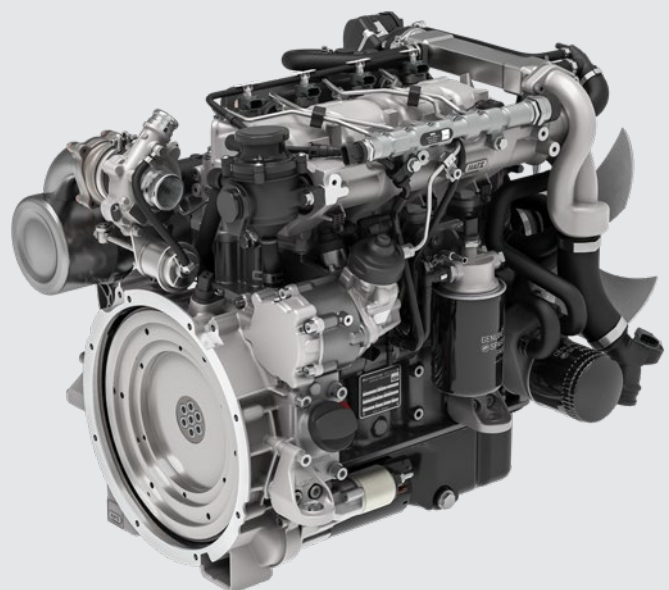

Not only the power counts. The internal values are also convincing.

Hatz has opted for premium products from well-known suppliers primarily from Germany for all the essential parts of the engine such as the injection system, crankcase, crankshaft, camshaft, exhaust gas recirculation valve, catalytic converter and sensor package.

Robust but lightweight construction

The engine crankcase is made from thin-walled gray cast iron, the cylinder head and cylinder head cover from cast aluminum, and the oil sump from sheet metal. All parts are optimised for lightweight construction and structural mechanics.

Basic features

- Three-/four-cylinder turbo common-rail diesel engine with 1.5 or 2.0 litres respectively
- Bosch off-highway common-rail system with 1800 bar
- Bosch injectors (off-highway version)
- Bosch high pressure pump with electrical lift pump
- Bosch rail
- Bosch ECU in 12 V or 24 V version, external
- Bosch starter motor & Bosch alternator
- High-tech cylinder head with optimised cooling and two-valve system
- Hydraulic valve tappets
- Wastegate turbo charger for optimised torque characteristics
- Intercooler (except 3H50T)
- Closed crankcase breather
- Gear wheel driven camshaft, no tooth belt, no chain

EGR mixing nozzle

- Perfect mixture of fresh air and recirculated exhaust gas
- Homogeneous combustion over all cylinders
- Optimised load on components and uniform wear

Bore/stroke ratio

Ideal bore/stroke ratio delivers an optimal thermodynamic surface to volume ratio, and therefore results in lower thermal losses at the cylinder walls

iHACS

iHACS

- Intelligent Hatz Advanced Combustion Strategy
- A Bosch ECU controls the torque-optimised combustion process developed by Hatz, with a focus on best real drive consumption and minimised noise emissions

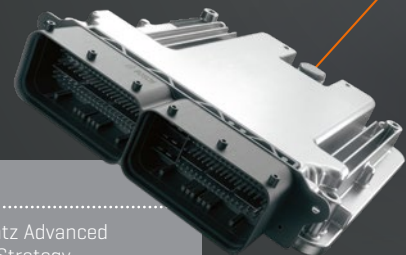

EGR cooler

High-quality stainless steel radiator with optimal cooling capacity and low pressure loss

Valve train

Hydraulic valve adjustment reduces maintenance costs

Bosch injector

- High-precision injection quantity control
- Highest injection pressures [1800 bar]
- Multiple injection for minimum noise emissions
- Worldwide use through special high-strength coatings for poor quality fuels

Pre-cooling unit

- Guaranteed highest long-term stability
- Outstanding cooling capacity with small installation space
- Low pressure losses
- Consistent component protection

Wastegate turbo charger

- Optimised for highest charge air pressures, best efficiencies and widest usable speed range
- Large height reserve

DOC

- Long-term stable
- Optimised for the full package
- High design flexibility

Piston

Optimised piston geometry for best emissions and minimised fuel consumption

Glow plug

High-temperature heater plug for extreme cold-start ability and white-smoke minimisation during warm-up

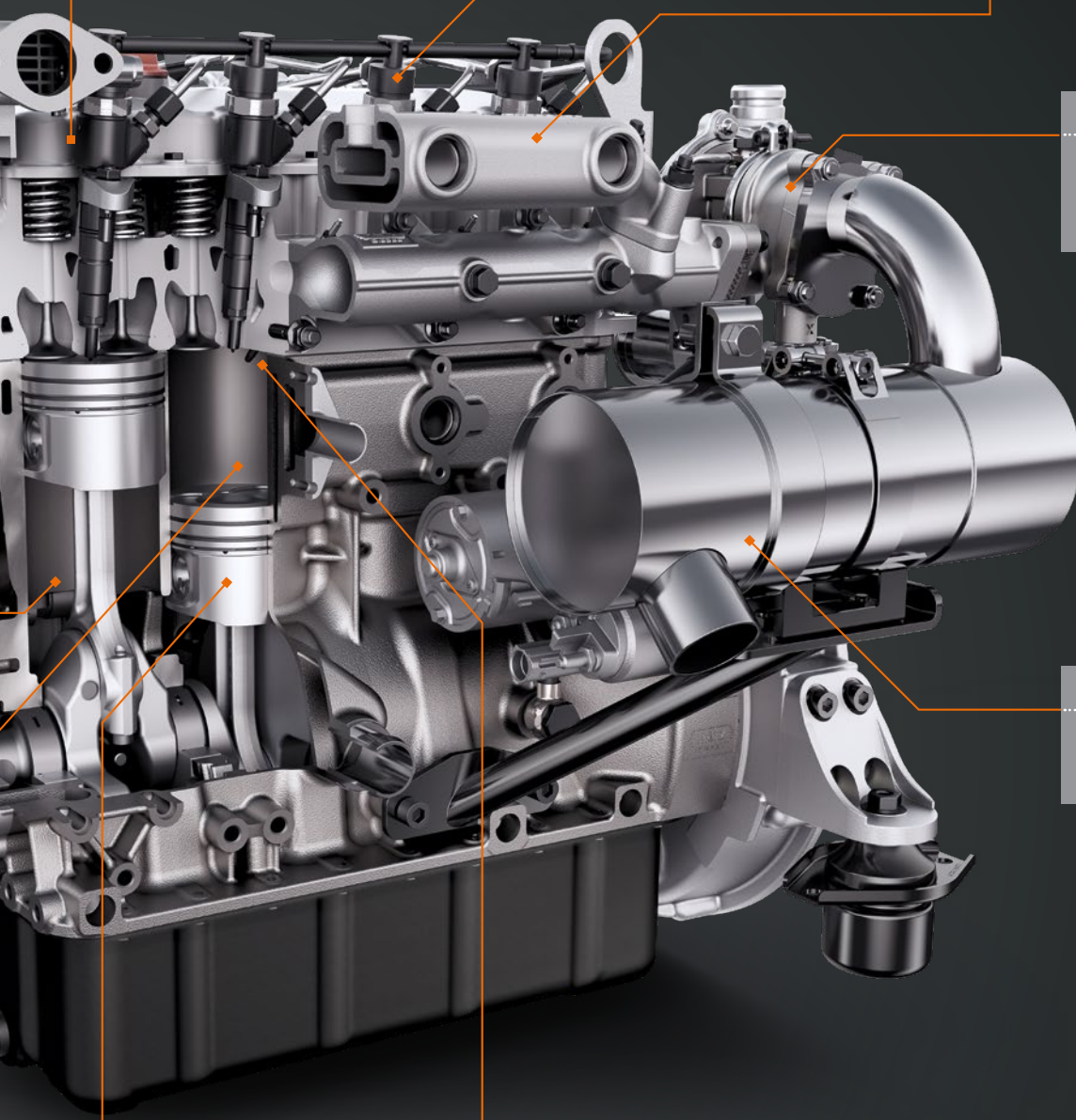

The new power package: Hatz 3H50.

Together with the well-established Hatz 4H50 engines, the newly developed three-cylinder engines will form the liquid-cooled product family of the H-series from 2018. Following the family concepts, the various 3H50 models are also orientated on the currently valid and future emission standards.

Developed for compact applications

The three-cylinder engines are the ideal solution for today's compact machine class smaller than 37 kilowatts. The goal is not only to house engines in a compact installation space: The form and operation of the machines must remain unchanged. As soon as exhaust emission after treatment becomes necessary, the little brother of the four-cylinder engine profits in particular from the compactness of the H-family.

Smaller space requirement, increased power

The automotive industry has been successfully practicing the downsizing concept for years. Three-cylinder engines inherited this concept as part of the H-family. Thus, the Hatz 3H50 at just 1.5 litres will replace engines with displacements over 2.5 litres in the future. The torque and response behaviour are considerably superior to the present generation. At the same time the consumption values are significantly reduced. In a word: right-sizing.

Compliant with emission standards

The Hatz 3H50TI doesn't need any exhaust emission after treatment at all. The engine achieves compliance with the EU Stage IIIA and US EPA Tier 4 Interim standards in the power range from 19 to 37 kilowatts.

Primarily for the US market and Canada as well as some Asian countries the Hatz 3H50TIC was developed. In order to ensure compliance with the emission standards US EPA Tier 4 final and EU Stage IIIB, the combination of EGR and DOC reduces substances potentially harmful to the environment to the required level.

In conjunction with the customised Hatz diesel particulate filter system optiHEAT, the Hatz 3H50TICD is optimally equipped for emission requirements such as EU Stage V. The engine model 3H50T with 18.4 kilowatts completes the range of H-series engines. 130 Newton metres make it the engine with the highest torque in its class in the market today. It fulfils emission standards US EPA Tier 4 final and EU Stage V without exhaust emission after treatment.

The models of the H-family.



NEW

3H50T

- Developed for performance class under 19 kW
- No intercooler, diesel oxidation catalyst (DOC) and exhaust gas recirculation (EGR) are needed
- Ideal solution for compact machines
- The highest torque in its class with a maximum output of 130 Nm
- Offers more torque than comparable engines in the class up to 37 kW and meets EU Stage V without DPF with less than 19 kW – thanks to downsizing
- Fulfils US EPA Tier 4 final/EU Stage V emissions regulations
- Emits extremely low particle mass [0.4 grams per kilowatt hour for EU Stage V]



3H50TI¹ / 4H50TI

- Basic engine (TIC) further developed for markets with low-quality fuel
- Components which react sensitive to sulfur like exhaust gas recirculation (EGR) and diesel oxidation catalyst (DOC) are avoided
- Fuel with up to 5000 ppm sulfur content possible
- Higher output compared to TIC model
- Higher ambient temperatures possible
- Fulfils US EPA Tier 2/EU Stage II emissions regulations
- Additionally EU Stage IIIA [19–37 kW] certified

¹ Available mid 2020

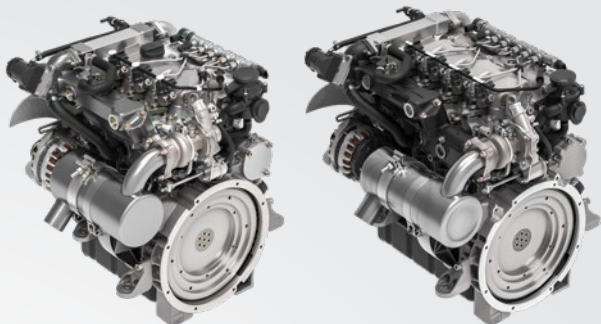

3H50TIC / 4H50TIC

- Turbo common-rail diesel engine
- World first downsizing industrial diesel engine
- Lowest consumption values in its class thanks to iHACS technology (intelligent Hatz Advanced Combustion Strategy)
- Thin-wall molding cylinder block, therefore compact in size and lightweight
- Hydraulic valve adjustment
- US EPA Tier 4 final and EU Stage IIIB compliance
- 3H50TIC also available as high torque version offering 16 Nm more torque



Open Power Unit (OPU)

- Radiator and intercooler mounted vibration-isolated
- Delivery as a complete system ex works
- Just application and all application-based external parts need to be connected
- Available as TICD, TIC, TI or T version

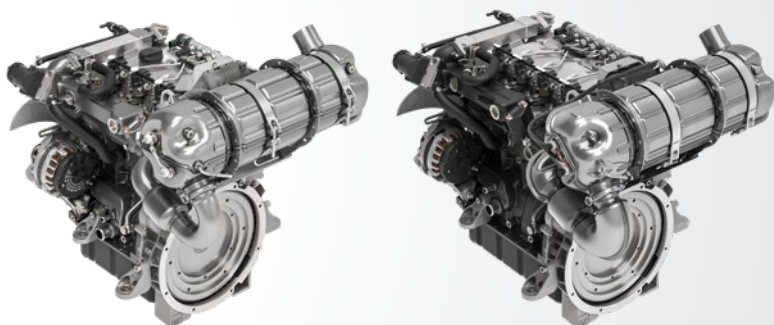

3H50TICD / 4H50TICD

- Basic engine (TIC) additionally equipped with separable DOC/DPF combination filter
- DPF system optiHEAT (optimised Hatz Exhaust After treatment Technology) optimally customisable to vehicle-/machine design
- Optimised for long operating periods between two regeneration intervals
- As complete system ex works or with DPF for chassis mounting
- Engineered for EU Stage V emission regulation

optiHEAT



New Silent Pack

- Based on OPU version but up to 60 % quieter
- Efficient weather and touch protection
- Easy accessibility of all control and service points
- Same high release temperature as non-encapsulated version
- Available for TICD, TIC and TI versions

Technical data 3H50

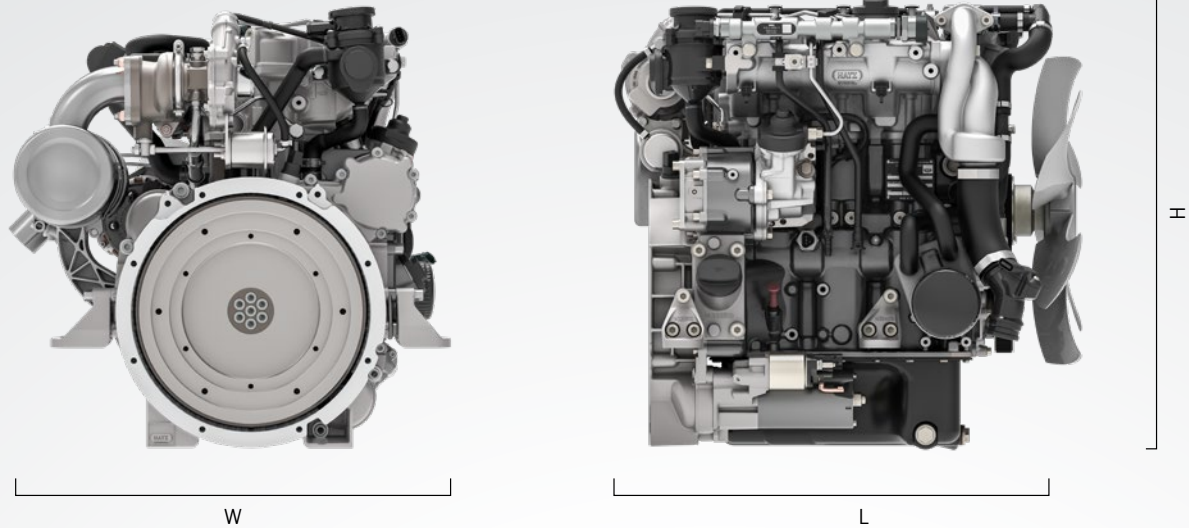

Engine type		3H50T	3H50TICD	3H50TIC	3H50TI ¹
Cylinders		3			
Displacement [l]		1.464			
After treatment		-	cEGR, DOC, DPF	cEGR, DOC	-
Power class [kW] of certification	EU Stage V	<19	19-56	-	-
	US EPA Tier 4 final	<19	19-56	19-56	-
	Less regulated	19-37	-	19-56	19-56
L x W x H [mm]		583 x 556 x 657	585 x 556 x 601	585 x 601 x 601 ²	583 x 556 x 601
Weight [kg]		132	140	154 ²	133
Max. output [kW @ rpm]		30 @ 3000	44 @ 2700-2800		48 @ 2300-2800
Max. torque [Nm @ rpm]		130 @ 1300-2100	203 @ 1800-2000	203 @ 1700-2000	202 @ 2100-2200
Options		OPU	OPU, New Silent Pack		

¹ Available mid 2020 ² Including engine mounted after treatment

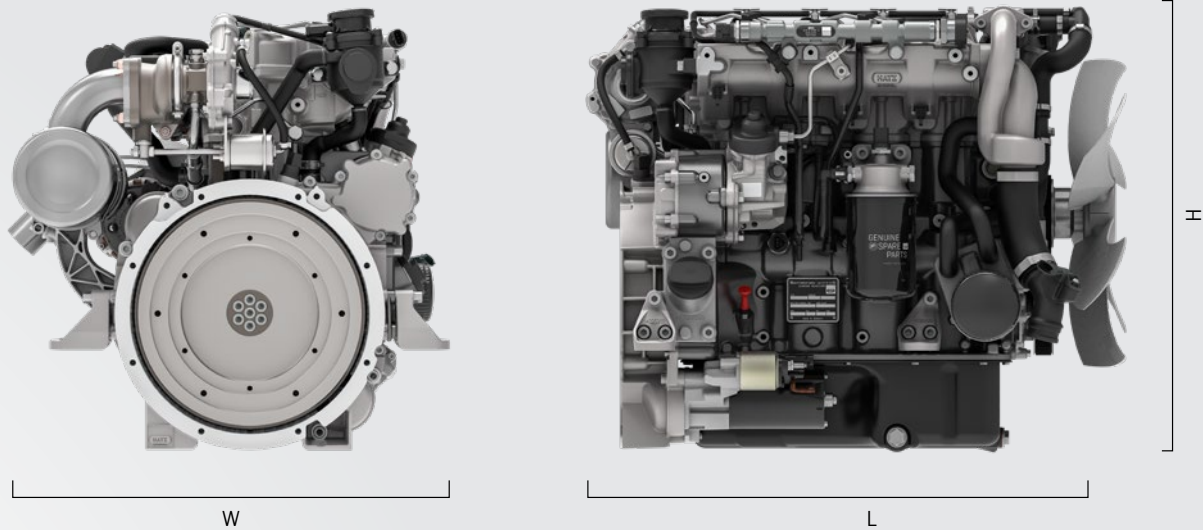

Engine type		4H50TICD	4H50TIC	4H50TI
Cylinders			4	
Displacement [l]			1.952	
After treatment		cEGR, DOC, DPF	cEGR, DOC	-
Power class [kW] of certification	EU Stage V	19-56	-	-
	US EPA Tier 4 final	19-56	19-56	-
	Less regulated	-	19-56	19-75
L x W x H [mm]		672 x 556 x 598	672 x 601 x 596 ²	670 x 556 x 592
Weight [kg]		158	173 ²	152
Max. output [kW @ rpm]		55 @ 2300-3000	55 @ 2500-2800	64 @ 2800
Max. torque [Nm @ rpm]		244 @ 2100	240 @ 1600-2100	268 @ 2100-2200
Options			OPU, New Silent Pack	

H-series – power ranges, emission classes and rated speeds

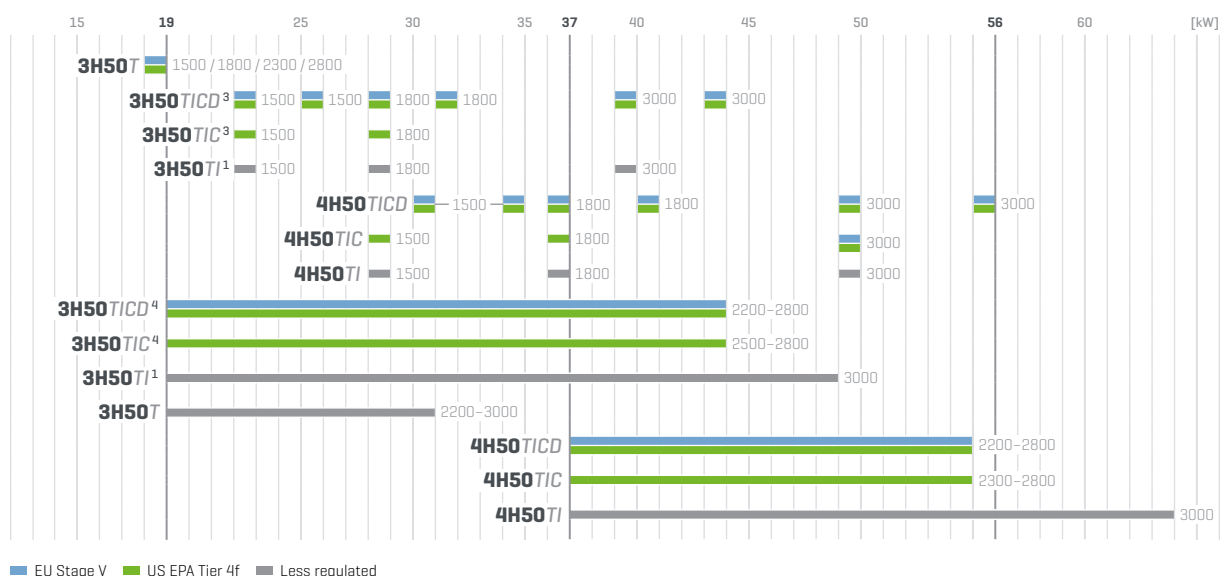

³ Constant speeds are planned to be available from end 2020 ⁴ Also available with 36.4 kW @ 2500 rpm for use in California without registration requirements

Motorenfabrik Hatz GmbH & Co. KG
Ernst-Hatz-Str. 16
94099 Ruhstorf a. d. Rott
Germany
Phone +49 8531 319-0
marketing@hatz-diesel.de
www.hatz-diesel.com



70254049 EN 02.20 Printed in the USA
Modifications, which serve technical
improvement, are reserved.



CREATING POWER SOLUTIONS.